

CONFIDENTIAL

VERTRAULICH

THIS DRAWING IS THE EXCLUSIVE PROPERTY OF MARQUARDT. WITHOUT THEIR CONSENT IT MAY NOT BE REPRODUCED OR GIVEN TO THIRD PARTIES.

Alle Rechte bei Marquardt, auch fuer den Fall von Schutzrechtsanmeldungen. Jede Veruegungsbefugnis, wie Kopier- und Weitergaberecht, bei uns.

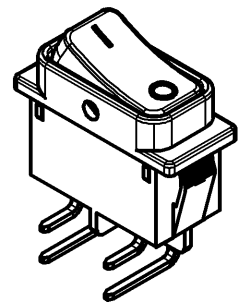
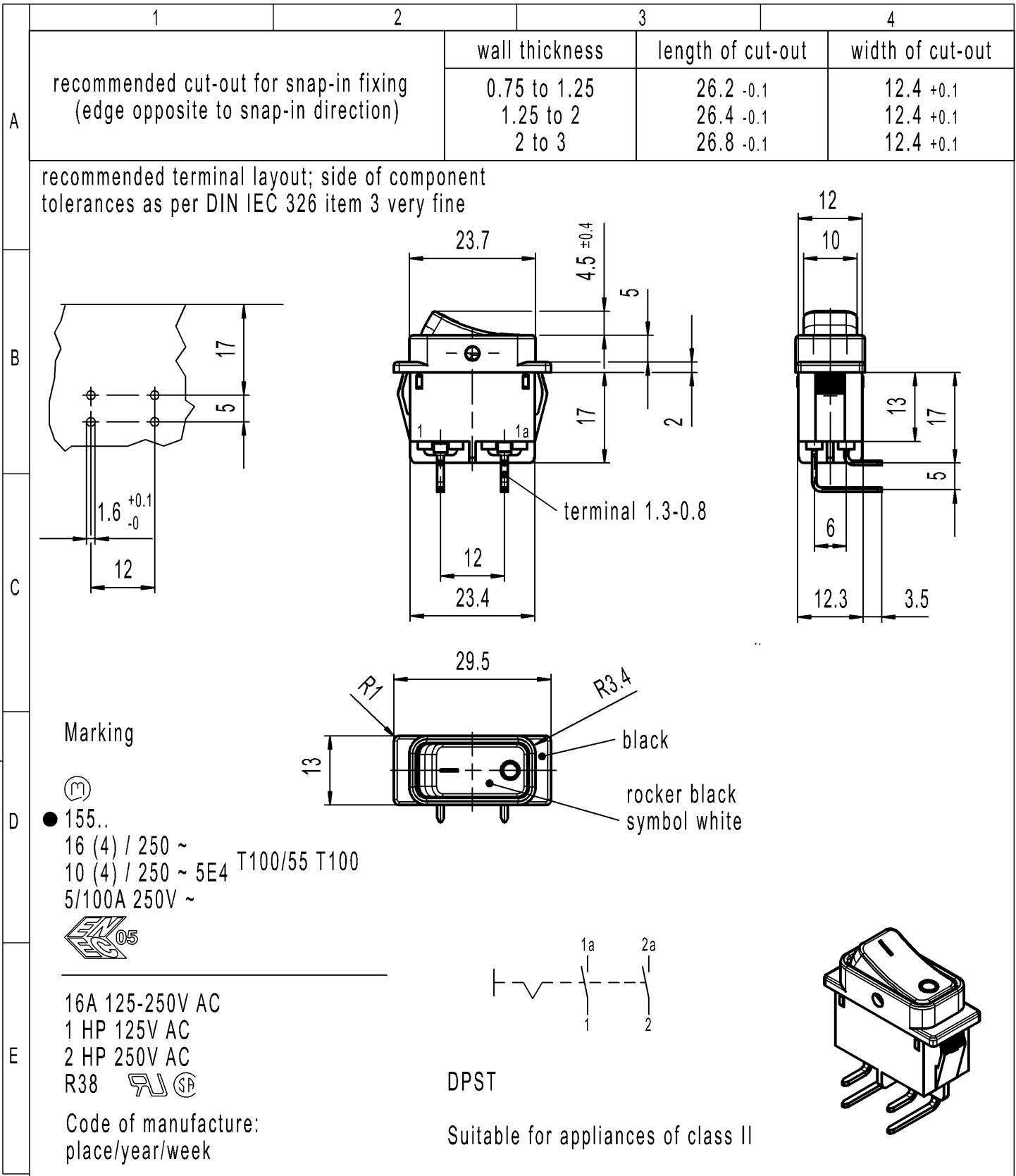

-	-	-	1552.4602-XX																																				
Figure	Type	Customer No.	Art.No.-PI																																				
Shape and location	Angle ± 2 °	Sheet 01																																					
	Edge tolerance	Ident. K	Document number 15524602																																				
⊙ ≡	<table border="1" style="width: 100%; border-collapse: collapse;"> <tr> <th colspan="2">Length</th> <th colspan="2">Radii</th> </tr> <tr> <td>0-6</td> <td>± 0.2</td> <td>0-6</td> <td>± 0.2</td> </tr> <tr> <td>>6-15</td> <td>± 0.4</td> <td>>6-15</td> <td>±</td> </tr> <tr> <td>>15-30</td> <td>± 0.4</td> <td>>15-30</td> <td>±</td> </tr> <tr> <td>>30-70</td> <td>±</td> <td>>30-200</td> <td>±</td> </tr> <tr> <td>>70-120</td> <td>±</td> <td></td> <td>±</td> </tr> <tr> <td>>120-200</td> <td>±</td> <td></td> <td>±</td> </tr> <tr> <td></td> <td>±</td> <td></td> <td>±</td> </tr> <tr> <td></td> <td>±</td> <td></td> <td>±</td> </tr> </table>	Length		Radii		0-6	± 0.2	0-6	± 0.2	>6-15	± 0.4	>6-15	±	>15-30	± 0.4	>15-30	±	>30-70	±	>30-200	±	>70-120	±		±	>120-200	±		±		±		±		±		±	Index g	Appliance Switch
		Length		Radii																																			
0-6	± 0.2	0-6	± 0.2																																				
>6-15	± 0.4	>6-15	±																																				
>15-30	± 0.4	>15-30	±																																				
>30-70	±	>30-200	±																																				
>70-120	±		±																																				
>120-200	±		±																																				
	±		±																																				
	±		±																																				
g	134536	2020-11-24	MATHPATIR																																				
f	69572	2010-10-11	HHE																																				
d	23635	1996-01-16	RS																																				
c	22971	1994-09-21	MUT																																				
Index	MEC-No.	Date (YYYY-MM-DD)	Edited by																																				
		All dimensions are in millimetres	System NX V11.0																																				
		Replacement of	Zg.gl.Nr.v.18.04.1988																																				